

CABLE TRAY SUPPORT SYSTEM 1200 x 1200 MM

SYSTEM DESCRIPTION

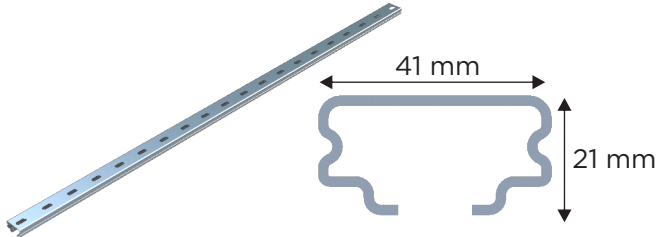

The uniquely designed Strut Channel is used to mount, support, and connect lightweight structural loads for supporting cable tray in Raised access floor system. These include Pipes, conduits, cable trays, electrical wires, data cables etc.

One of the obvious advantages of Strut channel for cable tray support structures is that we can easily achieve custom dimensions due to the infinitely adjustable nature of our strut. Various types of hot works and welding arrangements can be avoided which eventually results in time and money saving.

PERFORMANCE CONFORMING TO MASTER SPECS 10270 / 096900 (USA)

A: Structural Performance: CISCA A/F, 'Recommended Test Procedures for Access Floors'

STRUT CHANNEL DIMENSIONS	
Length	1154±1.0 mm
Width	41±0.50 mm
Height	21±0.50 mm
Thickness	1.50 / 1.80 mm
Material & Finish	G.I. 120 GSM

STRUT CHANNEL TEST METHODS

Test methods are recommended by CISCA - 2007. Mid Load 102kg (225 lbf) shall be applied vertically at mid span of the component, which held for minimum of one-minute duration of time. The load shall be relaxed and the mid span load at center of span with a permanent set not to exceed 0.010 inch (0.25 mm).

Note:

- The above mentioned loading parameters are derived & defined on the basis of the tests performed by the manufacturer based on the guidelines provided by the specified standards or as per manufacturer's recommendations.
- Manufacturer has all the rights to change or revise the specifications as and when applicable or required without the prior notice.

ALUMINUM CABLE TRAY SUPPORT HEAD

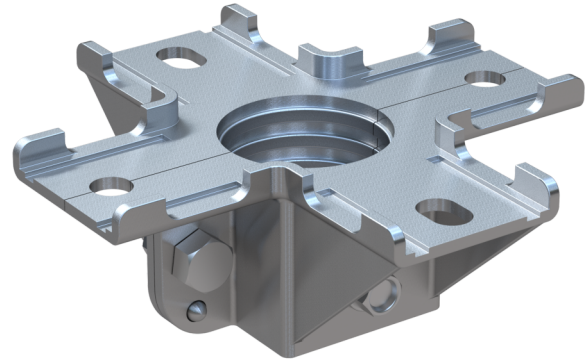

DIMENSIONS

Length	106.50 mm ±1.0 mm
Width	106.50 mm ±1.0 mm
Height	35 mm ±1.0 mm
Material	Aluminum die casting as per BS 1490
Suitable for 25.40 mm and 32.00 mm OD pipe	

