

UNITILE NEX-GEN 1200MMx1200MM EDGE SUPPORT RIGID GRID (ESRG) SYSTEM

PANEL ILLUSTRATION

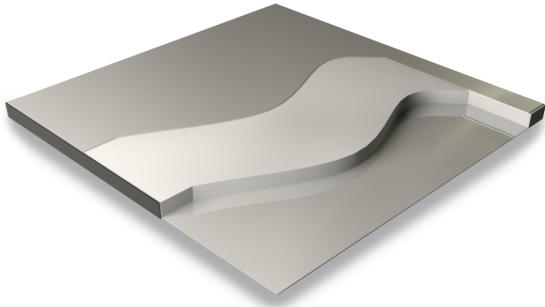

Category	Laminated, ESRG System
Panel size	600 x 600 mm
Core Material	Calcium Sulphate
Panel Core Thickness	34 mm
Panel Weight	20.3 kgs
Weight of System	61kg/m ² for FFH 300mm (varies with height)
Overall Floor Height	65 mm - 2000 mm

FEATURE BENEFITS

- ▶ Enhanced load-bearing capacity.
- ▶ Higher footprint area on pedestal head leading to enhanced stability & improved load carrying capacity.
- ▶ No overlapping of panels.
- ▶ Edge Support Design reduces the risk of damage to the panel edges during exposures to rolling and impact loads at site.
- ▶ Prevents fouling of cable tray systems with pedestals.
- ▶ Convenience of cable routing.
- ▶ Ease of post-handover maintenance for the lifecycle of the facility.
- ▶ Faster installations at site due to fewer pedestals
- ▶ Lesser obstruction to larger services running below floor (above 500 mm)

SYSTEM DESCRIPTION

Unitile Nex-Gen is a re-engineered raised access floor system re-engineered to overcome the challenges faced in data centers and control room environments.

The system has been designed to provide a wider span for cable management during the construction and the ease of maintenance post-handover of facility.

PANEL

Unitile Calcium Sulphate (UCS) access flooring system is manufactured using calcium sulphate core of 34 mm thickness imported from Knauf Germany having a very high density of 1700 Kgs /m³ of Natural gypsum. The panel is designed in a way it offers excellent acoustical sound deadening value, also offers a high degree of walking comfort ensuring perfect working environment. The panel also possesses electrostatic characteristics.

The panels are designed with pre-engineered cavity on all four corners to inter-lock with the pins on the PVC cap that leads to positive engagement between the pedestal and access floor panel. The factory-engineered interlocking design of the panel and the PVC cap enables positive alignment of the floor without any efforts during the installation and frequent access during service.

PEDESTAL

Pedestals installed to support the panel shall be suitable to achieve a specific finished floor height from the existing floor level and shall be placed 1200 mm distance in both directions to form a rigid grid of 1200 x 1200 mm. The pedestal design shall confirm speedy assembly and removal for relocation and maintenance. The Pedestal head assembly shall consist of a 147 x 147 x 3mm embossed Plus shape head mechanically riveted to a 19mm dia rolled formed stud of suitable length and 2 check nuts for level adjustment and arresting vertical movement. Pedestal shall be 25 mm diameter, 2 mm thick with a base plate size of 100 x 100 x 2 mm with a special head to support the 1200 mm span. Pedestal base shall be permanently secured in position on the subfloor by effective glue and screw/ anchor fasteners. Pedestals shall support an axial load of 2754 Kgs without deformation.

MAIN AND ANCILLARY RUNNERS

Main runner shall be of size 40 x 80 x 2 x 1198 mm (W x H x T x L) and secondary runner of size 40 x 80 x 2 x 1158 mm (W x H x T x L) which will form a grid of 1200 x 1200 mm. The box stringer of size 16 x 33 x 0.80 x 598 and 16 x 33 x 0.80 x 582 which will be secured over the main & secondary runner at 600 mm distance to form a grid of 600 x 600 mm to support the panel.

UNITILE NEX-GEN 1200MMx1200MM EDGE SUPPORT RIGID GRID (ESRG) SYSTEM

PRODUCT STRUCTURAL PERFORMANCE

(As per BSEN 12825)

CLASSIFICATION	DEFLECTION	CONCENTRATED LOAD
Class A	2.5 mm	1000 / 9.80 kgs / kN
Class B	3.0 mm	1200 / 11.76 kgs / kN
Class C	4.0 mm	1400 / 13.72 kgs / kN

PRODUCT STRUCTURAL PERFORMANCE

Ultimate Concentrated Load	1900 Kgs / 18.62 kN
Uniformly Distributed Load (UDL)	3000 kg/m ²
Stringer Load	102 Kgs (225 lbf)
Pedestal Axial Load Test	22 KN
Pedestal Over Turning Moment Test	113 N x Meters

OTHER STRUCTURAL PARAMETERS

Soft body impact	Tested as per (T12.03) of MOB PF2 PS Standards
Hard body impact	Tested as per (T12.03) of MOB PF2 PS Standards
Fire Rating	Class O & Class 1, as per BS 476 Part 6 (Fire Propagation) & 7 (Surface spread of flame). Rated REI 30 as per 1366-6 under BSEN 13501-2.

INSTALLATION TOLERANCE

Overall level before application of any load	± 1.5 mm over any 5.00 sq mt. ± 6 mm over any size of basic space.
Panel Level	+ 0.75 mm before the application of any load
Panel Interchangeability installation and removal	Interchangeable (except for field cut panels) & replaceable in any of the four directions at 90° increments

SPECIAL APPLICATIONS

Bridging Sections	Where obstructions prevent the use of pedestals
Ramp Pedestals	Pivot head pedestal to support angled ramp panels

PANEL CONSTRUCTION

The UCS floor panel is manufactured from 1700 kg/ mtr³ fiber reinforced calcium sulfate, which forms the core of the panel. Non- combustible high quality alpha-hemihydrate single pressed gypsum and non-toxic unbleached cellulose fibers are used as reinforcing material. The core is manufactured using a unique technique of compressing multiple layers of natural gypsum to guarantee homogenous density across the panel and have high resistance to water absorption.

The top surface of panel fully bonded with 2mm vinyl and bottom surface of panel fully bonded with GI sheet. The design incorporates a full depth ABS edge band, which while providing total encapsulation of the calcium sulphate core also protects the edge of the surface covering and resists ingress of moisture.

ELECTRICAL RESISTIVITY

As per ASTM F150/ NFPA 99 / ANSI S7.1 / CEI 61340 but modified for surface to ground. Tested at 100/500 volts:

Conductive range	2.5x10 ⁴ - 1x10 ⁶ Ohms (surface to ground)
------------------	--

FABRICATION TOLERANCE

Floor Panel Flatness	± 0.75 mm in any direction
Floor Panel Width or Length from specified size	± 0.50mm
Floor Panel Squareness	± 0.38mm

APPLICATIONS

Data Center Control Room

FACTORY BONDED FINISHES

Vinyl

UNDERSTRUCTURE

DETAILS VIEW : A

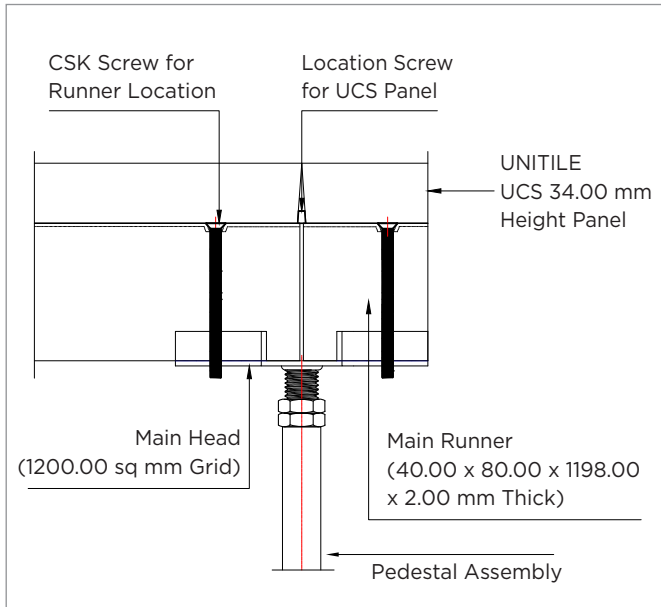

DETAILS VIEW : B

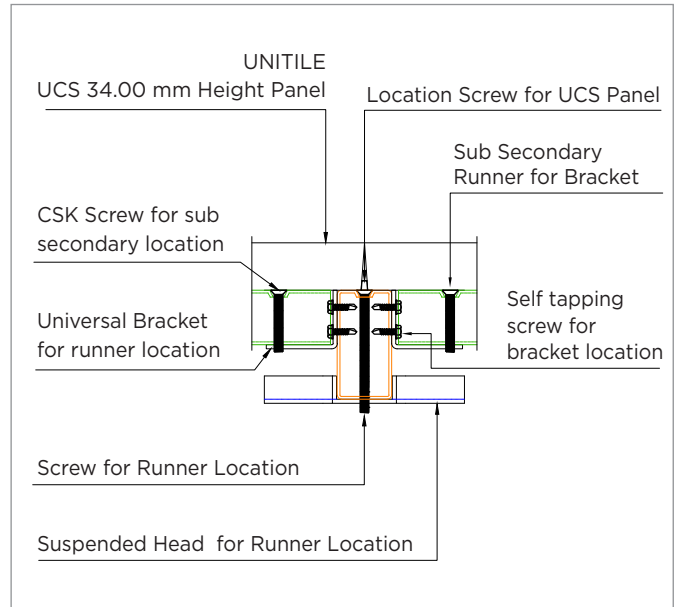

FRONT VIEW

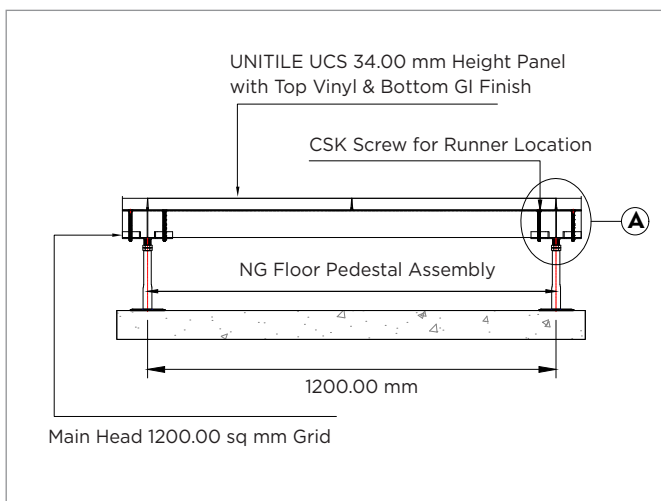

SECTION VIEW : "B-B"

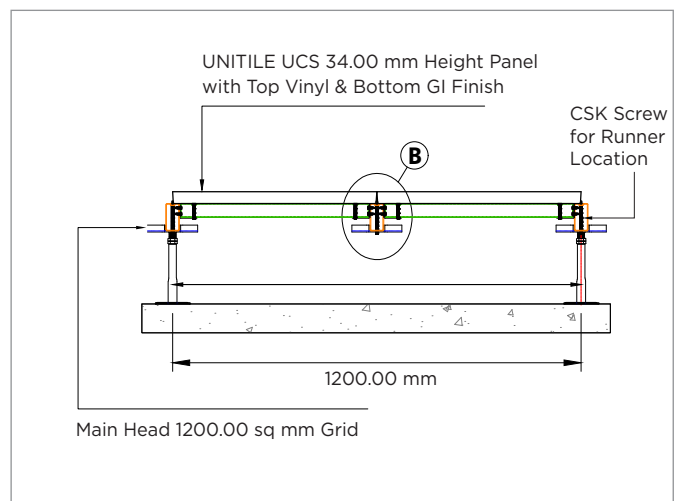

PANEL BOTTOM VIEW

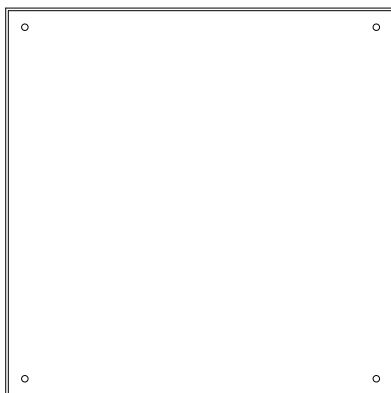

PANEL CONSTRUCTION

