

UNITILE UCB 35MM - PVC EDGE SUPPORT RIGID GRID (ESRG) SYSTEM

PANEL ILLUSTRATION

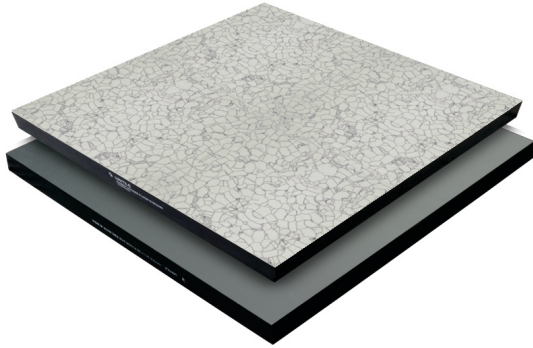

Category	ESRG System
Panel size	600 x 600 mm
Core Material	Chipboard
Panel Core Thickness	35 mm
Panel Weight	11 kgs
Weight of System	34kg/m ² for FFH 300mm (varies with height)
Overall Floor Height	150mm - 2000mm

FEATURE BENEFITS

- ▶ High strength to weight performance.
- ▶ Precision in floor levels and positive alignment with the understructure.
- ▶ Good acoustical properties.
- ▶ Unique In-built stringer design.

PANEL CONSTRUCTION

The UCB floor panel of 35 mm nominal thickness consists of engineered 600 x 600 mm square modular panels constructed around a 35 mm high-density E1 chipboard core strengthened with high-performance thermosetting resins.

The top & bottom surface of the core is fully bonded and laminated by Conductive Polyvinyl Chloride (PVC) & AL / GI sheet respectively & then trimmed to fine dimensional tolerances for modular control, accurate alignment of grids, inter-changeability of panels and prevention of creep. The design incorporates a full depth ABS edge band, which while providing total encapsulation of the chipboard core also protects the edge of the surface covering and resists ingress of moisture.

SYSTEM DESCRIPTION

PANEL:

Unitile Chipboard access floor panels are engineered to fine dimensional tolerances for modular control, accurate alignment of grids and inter-changeability of panels and for prevention of creep.

A full depth ABS edge band provides total encapsulation of chipboard and protects the edge of surface covering to prevent ingress of moisture. Since electrical continuity is maintained through conductive gasket, the positive positioning and location of the floor panel onto the understructure is ensured.

The panels are designed with pre-engineered cavity on all four corners to inter-lock with the pins on the PVC cap that leads to positive engagement between the pedestal and access floor panel. The factory-engineered Inter-locking design of the panel and the PVC cap enables positive alignment of the floor without any efforts during the installation and frequent access during service.

PEDESTAL:

The pedestal assembly shall provide easy adjustment of leveling and accurately align panels for a maximum ± 25 mm in the vertical direction. The Pedestal head assembly shall consist of embossed head mechanically riveted to a rolled formed stud and 2 check nuts for level adjustment and arresting vertical movement. The pedestal head shall consist of an anti-vibration conductive cap with inbuilt isolating spacers for Panel and stringer location.

STRINGERS:

The stringer shall be continuous box type, for strength, lateral stability, and for enhanced rolling load performance and to support the panels on all four sides for alignment without leaving any gap at the pedestal head preventing air leakage.

The box tabular section provides a higher footprint area for the panel to rest that improves load carrying performance of the floor. The continuous stringer on both sides fully supports the panel edges and minimizes air leakage.

UNITILE UCB 35MM - PVC

EDGE SUPPORT RIGID GRID (ESRG) SYSTEM

PRODUCT STRUCTURAL PERFORMANCE

(As per BSEN 12825)

CLASSIFICATION	DEFLECTION	CONCENTRATED LOAD
Class A	2.5 mm	525 / 5.15 kgs / kN
Class B	3.0 mm	600 / 5.88 kgs / kN
Class C	4.0 mm	720 / 7.05 kgs / kN

Ultimate Concentrated Load	1650 Kgs / 16.18kN
Uniformly Distributed Load (As per PSA MOB PF2 PS)	1377 / SQM
Stringer Load	102 Kgs (225 lbf)
Pedestal Axial Load Test	22 kN
Pedestal Over Turning Moment Test	113 N x Meters

OTHER STRUCTURAL PARAMETERS

Soft body impact	Tested as per (T12.03) of MOB PF2 PS Standards
Hard body impact	Tested as per (T12.03) of MOB PF2 PS Standards

ELECTRICAL RESISTIVITY

As per ASTM F150 Special Applications tested at 500 volts:

Conductive range	$2.5 \times 10^4 - 1 \times 10^6$ Ohms (surface to ground)
------------------	---

SPECIAL APPLICATIONS

Bridging Sections	Where obstructions prevent the use of pedestals
Ramp Pedestals	Pivot head pedestal to support angled ramp panels

APPLICATIONS

- Data Center
- Computer Room
- Server / Hub Room
- Switch Room
- Communication Room
- Control room

FACTORY BONDED FINISHES

- PVC

INSTALLATION TOLERANCE

Overall level before application of any load	± 1.5 mm over any 5.00 sq mt. ± 6 mm over any size of basic space.
Panel Level	+ 0.75 mm before the application of any load
Panel Interchangeability installation and removal	Interchangeable (except for field cut panels) & replaceable in any of the four directions at 90° increments

FABRICATION TOLERANCE

Floor Panel Flatness	± 0.75 mm in any direction
Floor Panel Width or Length from specified size	± 0.50 mm
Floor Panel Squareness	± 0.38 mm

PANEL CONSTRUCTION

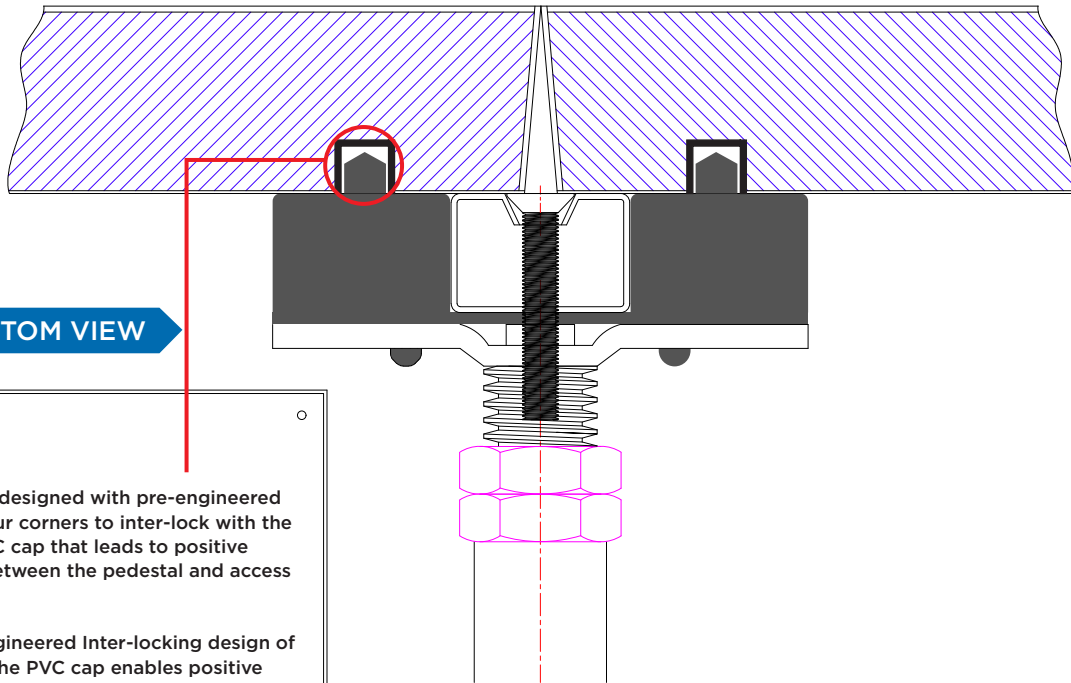

PANEL BOTTOM VIEW

- The panels are designed with pre-engineered cavity on all four corners to inter-lock with the pins on the PVC cap that leads to positive engagement between the pedestal and access floor panel.
- The factory-engineered Inter-locking design of the panel and the PVC cap enables positive alignment of the floor without any efforts during the installation and frequent access during service.

UNDERSTRUCTURE

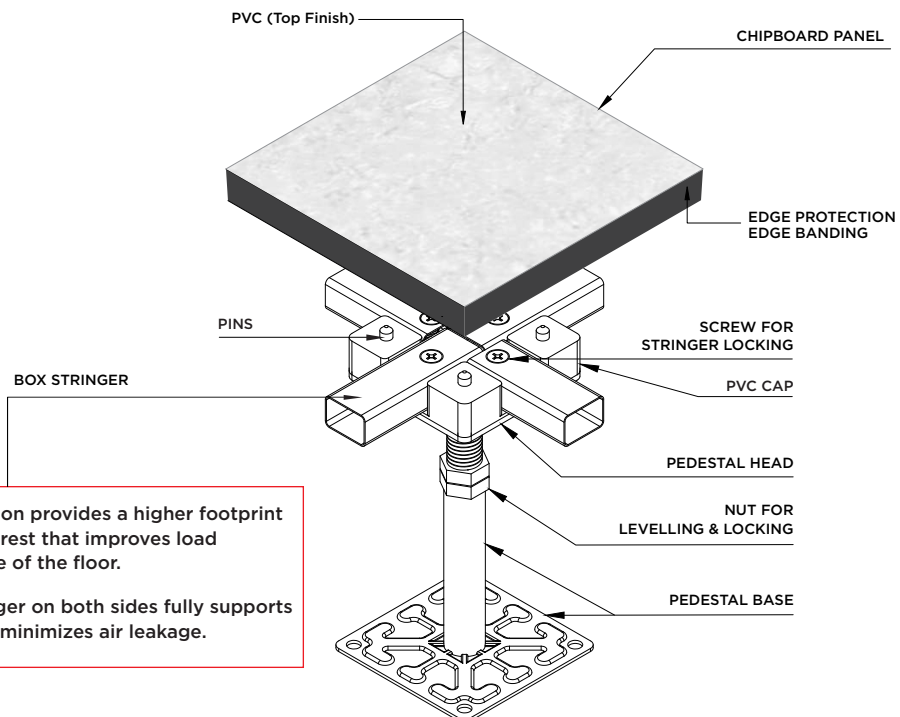

- The box tabular section provides a higher footprint area for the panel to rest that improves load carrying performance of the floor.
- The continuous stringer on both sides fully supports the panel edges and minimizes air leakage.