

UNITILE CALCIUM SULPHATE (UCS) - GI EDGE SUPPORT RIGID GRID (ESRG) SYSTEM

PANEL ILLUSTRATION

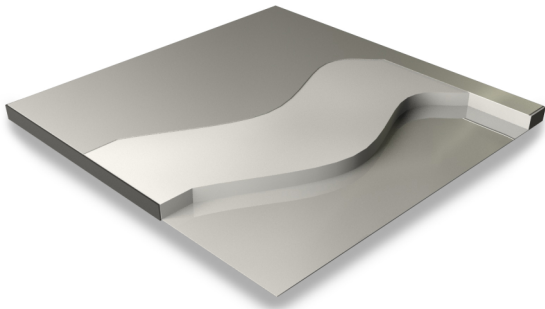

Category	GI / GI ESRG System
Panel size	600 x 600 mm
Core Material	Calcium Sulphate
Panel Core Thickness	34 mm
Edge Band	PVC
Panel Weight	22.150 Kgs
Weight of System	64 Kgs / m ² for FFH 300mm (varies with height)
Overall Floor Height	150 mm - 2000 mm

FEATURE BENEFITS

- ▶ High strength to weight performance.
- ▶ Excellent fire resistance properties tested as per Class O and Class 1 standards.
- ▶ Precision in floor levels and positive alignment with the understructure.
- ▶ Good acoustical properties.
- ▶ Unique In-built stringer design.
- ▶ 90-97% UCS panels can be recycled at the end of their life.

APPLICATIONS

- Open Office

FACTORY BONDED FINISHES

- GI

SYSTEM DESCRIPTION

PANEL:

Unitile Calcium Sulphate (UCS) access flooring panel is manufactured from fiber reinforced calcium sulphate which forms the core of the panel having density of 1400-1600 Kgs /mtr³. It offers excellent acoustical sound deadening value and a high degree of walking comfort ensuring perfect working environment.

The top & bottom surface of the core is fully bonded by GI and GI respectively & then trimmed to fine dimensional tolerances for modular control, accurate alignment of the grids, interchangeability of panels and prevention of creep. The design incorporates a full depth PVC edge band, which while providing total encapsulation of the calcium sulphate core also protects the edge of the surface covering and resists ingress of moisture.

PEDESTAL:

The pedestal assembly shall provide easy adjustment of leveling and accurately align panels for a maximum ± 25 mm in the vertical direction. The Pedestal head assembly shall consist of embossed head mechanically riveted to a rolled formed stud and 2 check nuts for level adjustment and arresting vertical movement. The pedestal head shall consist of an anti-vibration conductive cap with inbuilt isolating spacers for Panel and stringer location.

STRINGERS:

The stringer shall be continuous box type, for strength, lateral stability, and for enhanced rolling load performance and to support the panels on all four sides for alignment without leaving any gap at the pedestal head preventing air leakage. The understructure is designed with pre-engineered flaring on the stringer for positive engagement of the access floor panel.

All steel components shall be Galvanized & Electro plated as per manufacturers offered system & standard practices.

The box tabular section provides a higher footprint area for the panel to rest that improves load carrying performance of the floor. The continuous stringer on both sides fully supports the panel edges and minimizes air leakage.

UNITILE CALCIUM SULPHATE (UCS) - GI EDGE SUPPORT RIGID GRID (ESRG) SYSTEM

PRODUCT STRUCTURAL PERFORMANCE

(As per BSEN 12825)

Concentrated Load	725 Kgs (7.10 kN)
Ultimate Concentrated Load	1490 Kgs / 14.60 kN
Uniformly Distributed Load (As per PSA MOB PF2 PS/CISCA)	2175 Kgs / m ²
Stringer Load	102 Kgs (225 lbf)
Pedestal Axial Load Test	22 kN
Pedestal Over Turning Moment Test	113 N x Meters

OTHER STRUCTURAL PARAMETERS

Soft body impact	Tested as per (T12.03) of MOB PF2 PS Standards
Hard body impact	Tested as per (T13.03) of MOB PF2 PS Standards
Fire Rating	En1366 Part 6 : 2005 & En1366 Part 1 : 1999

INSTALLATION TOLERANCE

Overall level before application of any load	± 1.5 mm over any 5.00 sq mt. ± 6 mm over any size of basic space
Panel Level	+ 0.75 mm before the application of any load
Panel Interchangeability installation and removal	Interchangeable (except for field cut panels) & replaceable in any of the four directions at 90° increments

FABRICATION TOLERANCE

Floor Panel Flatness	+ 0.75 mm in any direction
Floor Panel Width or Length from specified size	± 0.50mm
Floor Panel Squareness	± 0.38mm

SPECIAL APPLICATIONS

Bridging Sections	Where obstructions prevent the use of pedestals
Ramp Pedestals	Pivot head pedestal to support angled ramp panels

Note:

- The above mentioned loading parameters are derived & defined on the basis of the tests performed by the manufacturer based on the guidelines provided by the specified standards or as per manufacturer's recommendations.
- Manufacturer has all the rights to change or revise the specifications as and when applicable or required without the prior notice.

PANEL CONSTRUCTION

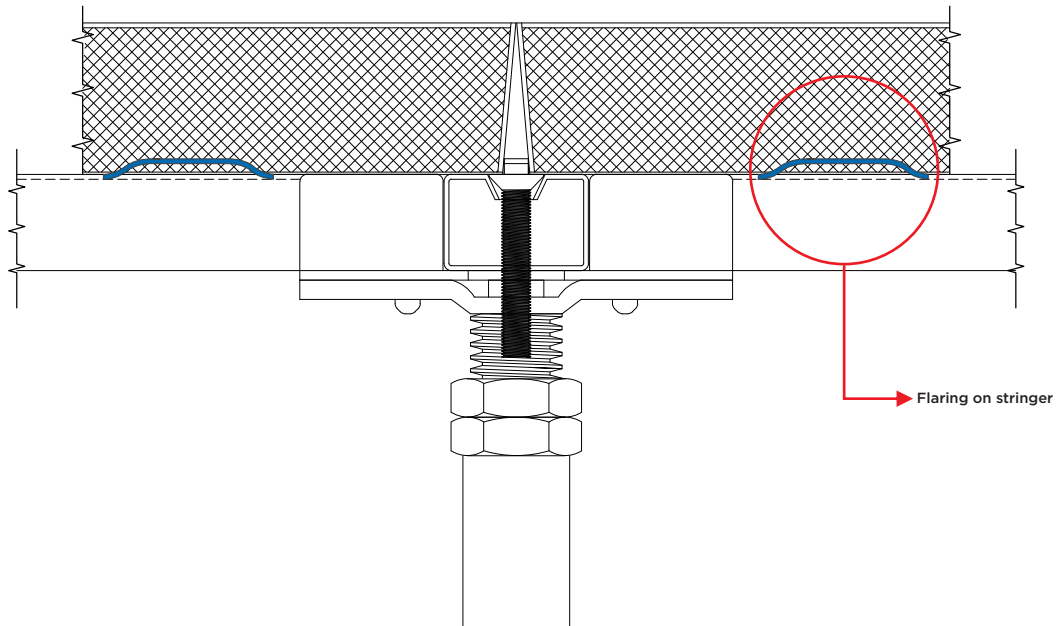

PVC EDGE BAND

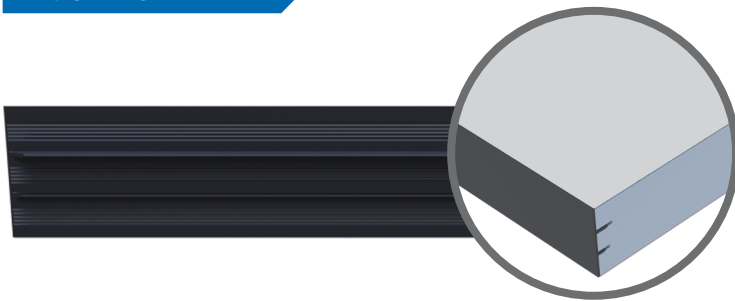

UNDERSTRUCTURE

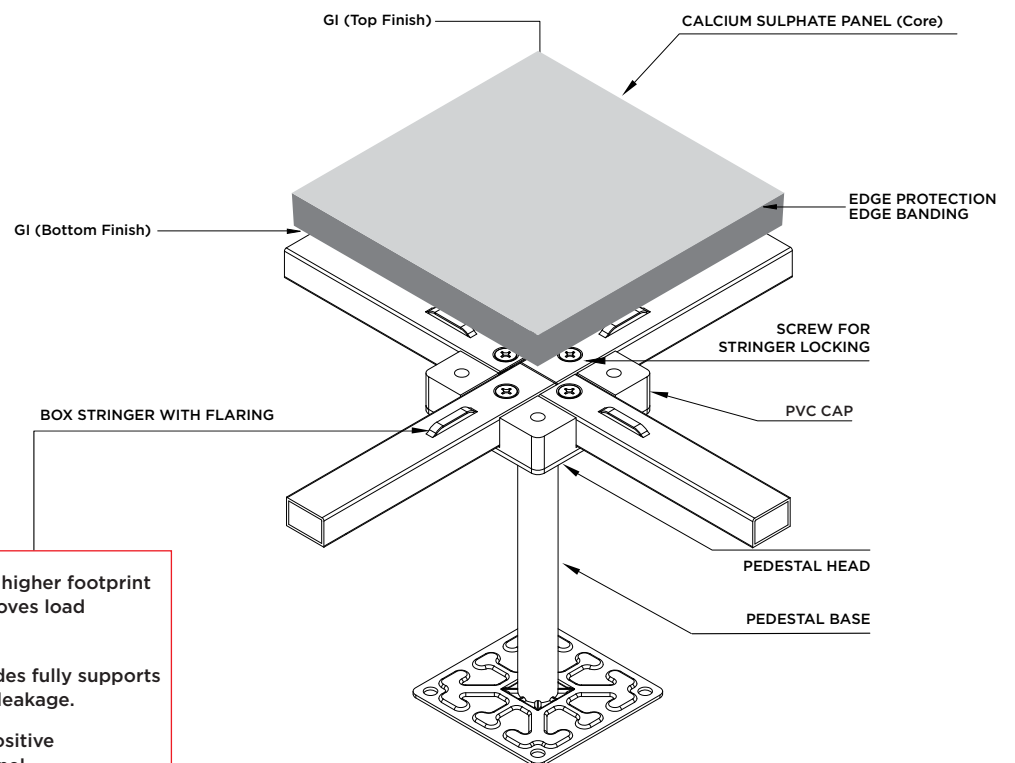

- The box tabular section provides a higher footprint area for the panel to rest that improves load carrying performance of the floor.
- The continuous stringer on both sides fully supports the panel edges and minimizes air leakage.
- Flaring on the stringer enhances positive engagement of the access floor panel